

U-Type Plate Nut

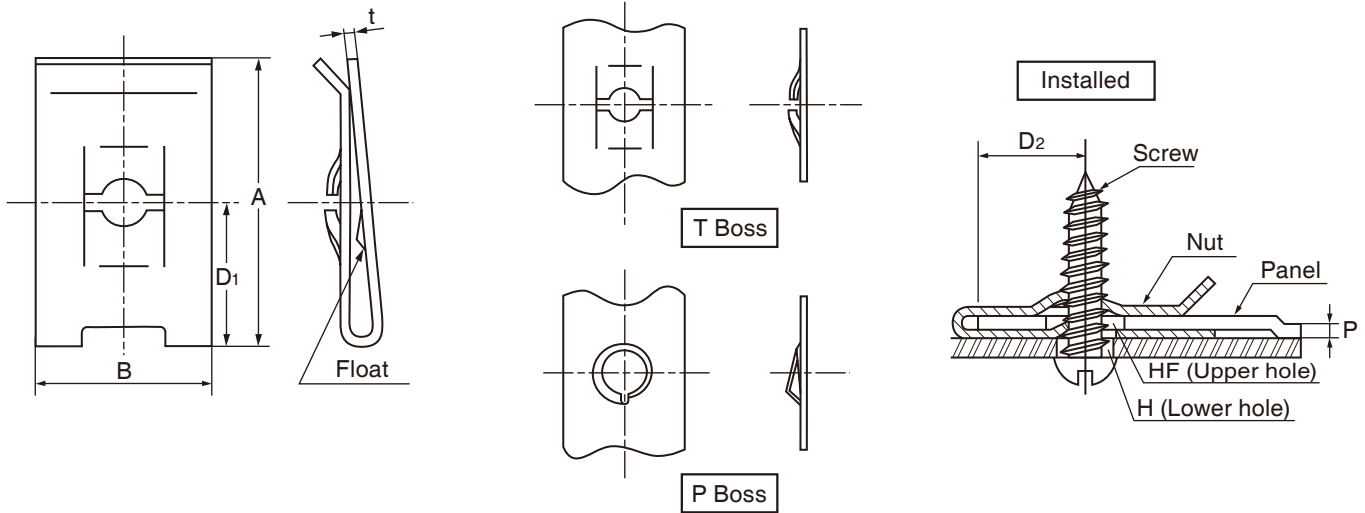

Unit: mm

| Size No. | Applicable screw (Note 1) | Nuts | | | | Remarks | | | Panel size | | | | |
|----------|---------------------------|------|------|----------------|------|---------|---------|---------------------|------------|------|---------------------|-----|-----|
| | | A | B | D ₁ | t | Boss | Float | Material | P | | D ₂ Max. | H | HF |
| | | | | | | | | | Min. | Max. | | | |
| USN-3001 | M3 × 0.5 | 18 | 11.2 | 9 | 0.3 | T | With | Carbon spring steel | 0.6 | 1 | 7.5 | 4 | 5.5 |
| 3006 | M3 × 0.5 | 11.5 | 8 | 6 | 0.3 | P | Without | SUS | 0.6 | 1.2 | 4.5 | 4 | 4 |
| 3012 | 3 - 24-thread | 11.5 | 8 | 6 | 0.45 | P | Without | SUS | 0.6 | 1.2 | 4.5 | 4 | 4 |
| 4001 | M4 × 0.7 | 20 | 12.7 | 10 | 0.4 | T | With | Carbon spring steel | 0.7 | 1.2 | 8 | 5 | 7 |
| 4003 | M4 × 0.7 | 16.5 | 9 | 10 | 0.4 | P | Without | SUS | 0.8 | 1.2 | 8 | 5 | 5 |
| 4004 | 4 - 16-thread | 20 | 12.7 | 10 | 0.8 | T | With | Carbon spring steel | 0.8 | 1.5 | 8 | 5 | 7 |
| 4005 | 4 - 16-thread | 20 | 12.7 | 10 | 0.8 | P | Without | Carbon spring steel | 1 | 1.6 | 8 | 5 | 6 |
| 4006 | 4 - 16-thread | 16.3 | 11 | 8.3 | 0.6 | T | With | Carbon spring steel | 1 | 1.6 | 6.5 | 5 | 7 |
| 4007 | 4 - 16-thread | 20 | 12.7 | 13 | 0.45 | T | Without | Carbon spring steel | 2 | 2.7 | 10 | 5 | 6 |
| 4024 | 4 - 16-thread | 17 | 11 | 9.1 | 0.6 | T | Without | Carbon spring steel | 0.7 | 1.6 | 7 | 5 | 7 |
| 4026 | 4 - 16-thread | 16 | 11 | 8 | 0.5 | P | With | SUS | 2 | 2.5 | 6 | 5 | 6 |
| 4031 | 4 - 18-thread | 19 | 9 | 13 | 0.45 | P | Without | Carbon spring steel | 2 | 3 | 10 | 5 | 5 |
| 4037 | M4 × 0.7 | 18 | 9 | 12 | 0.4 | P | Without | SUS | 1 | 1.2 | 10 | 5 | 6 |
| 4048 | 4 - 16-thread | 24 | 11 | 17 | 0.6 | T | With | Carbon spring steel | 0.7 | 1.6 | 14.5 | 5 | 7 |
| 5001 | M5 × 0.8 | 20 | 12.7 | 10 | 0.45 | T | With | Carbon spring steel | 0.7 | 1.2 | 8 | 6.5 | 8 |
| 5003 | 5 - 12-thread | 20 | 13 | 11.5 | 0.7 | T | Without | Carbon spring steel | 1 | 2.3 | 9 | 6.5 | 7 |
| 5004 | 5 - 16-thread | 19.6 | 13 | 11.6 | 0.6 | P | With | Carbon spring steel | 0.7 | 1.5 | 10 | 6.5 | 7.5 |
| 5008 | 5 - 16-thread | 32.2 | 12.7 | 22.2 | 0.7 | P | With | Carbon spring steel | 1 | 2.6 | 19 | 6.5 | 8 |
| 5016 | 5 - 16-thread | 16.2 | 12.7 | 8.7 | 0.7 | P | Without | Carbon spring steel | 0.8 | 1.6 | 7 | 6.5 | 6.5 |
| 5017 | M5 × 0.8 | 21 | 12.7 | 11.5 | 0.4 | T | Without | Carbon spring steel | 1.3 | 2 | 9 | 6.5 | 8 |
| 6001 | M6 × 1 | 20 | 12.7 | 10 | 0.5 | T | With | Carbon spring steel | 0.7 | 1.2 | 8 | 7.5 | 9.5 |
| 6002 | 6 - 10-thread | 21.8 | 12.7 | 11.3 | 0.8 | P | Without | Carbon spring steel | 0.6 | 1.2 | 9.5 | 7.5 | 7.5 |

Material = Carbon spring steel Hardness = 40 through 50HRC (38-45HRC only for USN-4024)

Material = Stainless steel for spring

Notes

1. Refer to the JIS standard for the thread size.
2. Our products with little marketability may not be in stock. When employing our products, consult with us for their availability.

U-Type Wide Plate Nut

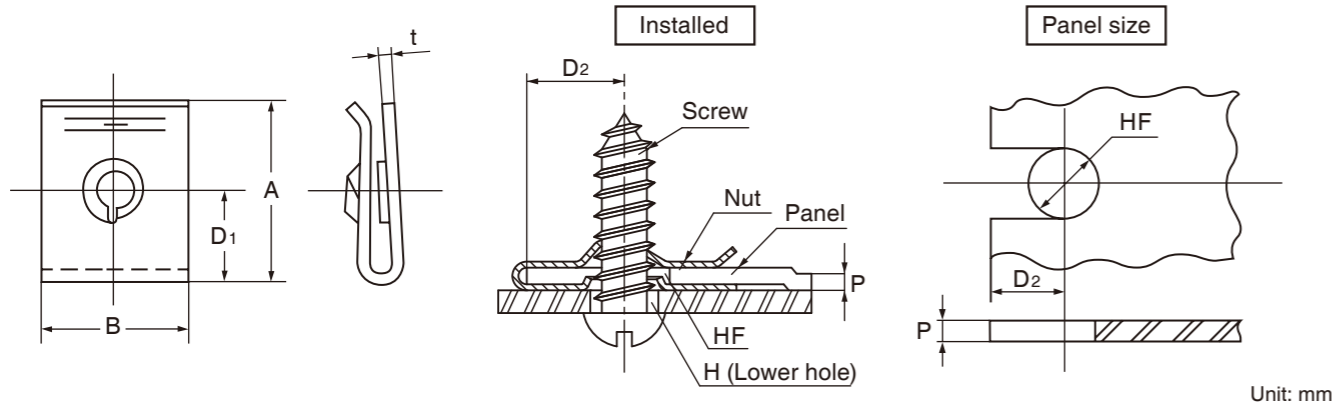

| Size No. | Applicable screw | Nuts | | | | Remarks | | | Panel size | | | | |
|----------|------------------|------|----|----------------|-----|---------|-------|----------|------------|-----|----------------|-----|----|
| | | A | B | D ₁ | t | Boss | Float | Material | P | | D ₂ | H | HF |
| USN-4009 | M4 × 0.7 | 11.4 | 11 | 5.9 | 0.4 | P | With | SUS | 0.7 | 0.9 | 5 | 4.5 | 6 |
| 4015 | M4 × 0.7 | 12.4 | 11 | 5.9 | 0.4 | P | With | SUS | 2.5 | 2.8 | 4 | 4.5 | 6 |
| 4035 | 4 - 16-thread | 12.4 | 11 | 5.9 | 0.4 | P | With | SUS | 0.7 | 0.9 | 5 | 4.5 | 6 |
| 4036 | 4 - 16-thread | 12.4 | 11 | 5.9 | 0.4 | P | With | SUS | 2.5 | 2.8 | 4 | 4.5 | 6 |

Material = Stainless steel for spring

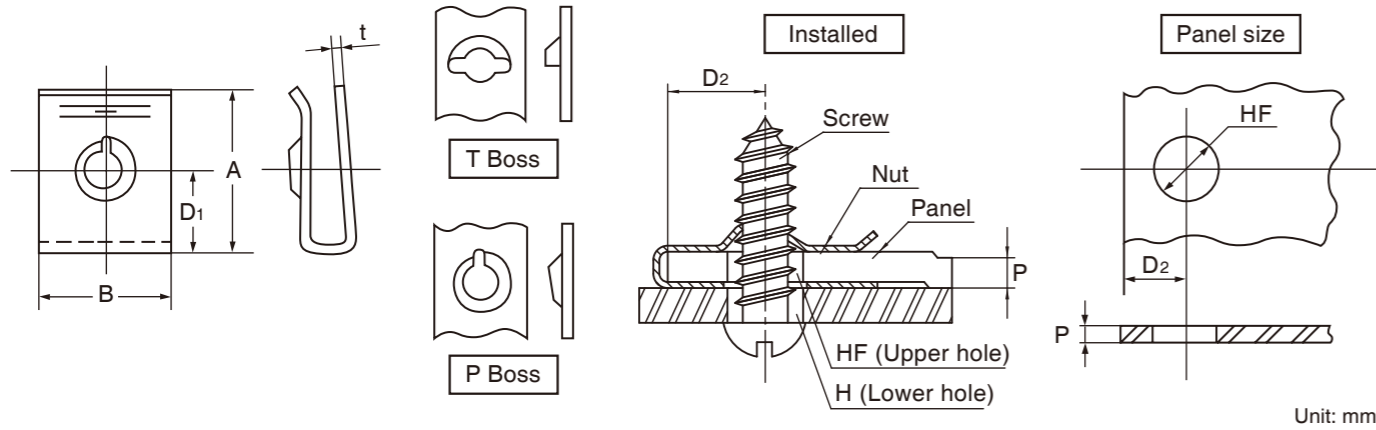

| Size No. | Applicable screw | Nuts | | | | Remarks | | | Panel size | | | | |
|----------|------------------|------|----|----------------|-----|---------|---------|---------------------|------------|-----|----------------|---|----|
| | | A | B | D ₁ | t | Boss | Float | Material | P | | D ₂ | H | HF |
| USN-4043 | 4 - 18-thread | 10 | 10 | 5.5 | 0.5 | T | Without | Carbon spring steel | 2.6 | 2.7 | 4.5 | 5 | 5 |
| 5021 | 5 - 12-thread | 20.5 | 17 | 9 | 0.7 | P | Without | SUS | 6 | 7 | 7.5 | 6 | 7 |
| 5023 | 5 - 16-thread | 14.5 | 11 | 8.6 | 0.6 | P | Without | Carbon spring steel | 2 | 3.5 | 7 | 6 | 6 |
| 5026 | 5 - 16-thread | 11 | 10 | 6 | 0.5 | T | Without | Carbon spring steel | 2.6 | 2.7 | 5 | 6 | 6 |

Material = Carbon spring steel

Material = Stainless steel (SUS304-CS)

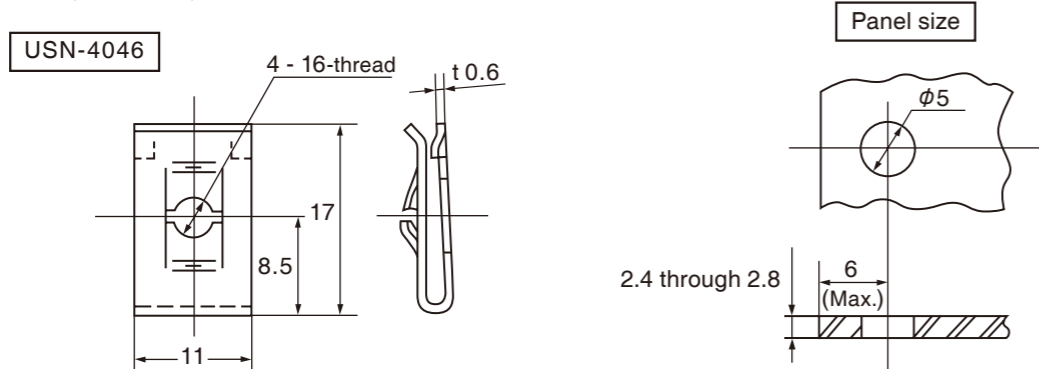

Notes

1. Refer to the JIS standard for the thread size.
2. Our products with little marketability may not be in stock. When employing our products, consult with us for their availability.

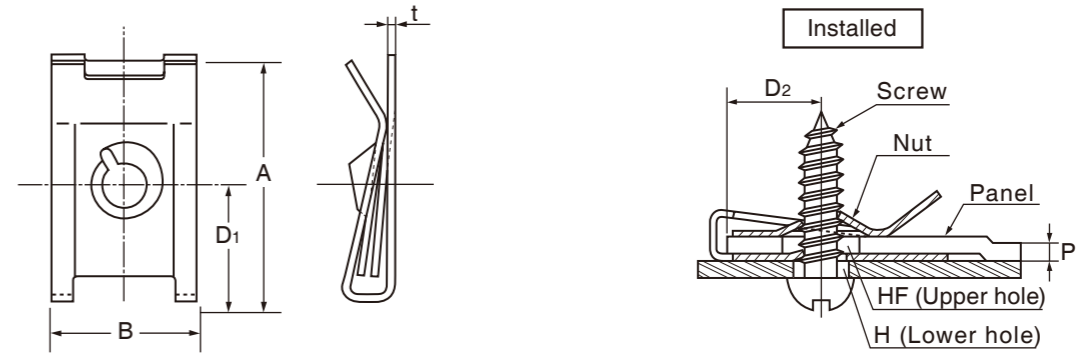

| Size No. | Applicable screw (Note 1) | Nuts | | | | Remarks | Panel size | | | | |
|-----------|---------------------------|------|------|----------------|-----|---------|------------|-----|----------------|---|----|
| | | A | B | D ₁ | t | | P | | D ₂ | H | HF |
| WUSN-4039 | 4 - 18-thread | 21.6 | 12.7 | 10.1 | 0.6 | With | 0.7 | 2.5 | 8 | 5 | 7 |
| 4044 | 4 - 18-thread | 16.6 | 13.5 | 8.6 | 0.6 | Without | 0.6 | 2 | 7 | 5 | 6 |
| 5022 | 5 - 16-thread | 21.7 | 12.7 | 10.2 | 0.7 | With | 0.7 | 3.1 | 8 | 6 | 8 |
| 5025 | 5 - 16-thread | 20.6 | 13.5 | 9.5 | 0.6 | Without | 0.6 | 3.8 | 8 | 6 | 7 |
| 5029 | 5 - 16-thread | 21.7 | 12.7 | 10.2 | 0.7 | Without | 2 | 3 | 8 | 6 | 7 |

Material = Carbon spring steel

Notes

1. Refer to the JIS standard for the thread size.
2. Our products with little marketability may not be in stock. When employing our products, consult with us for their availability.

F-Type Plate Nut

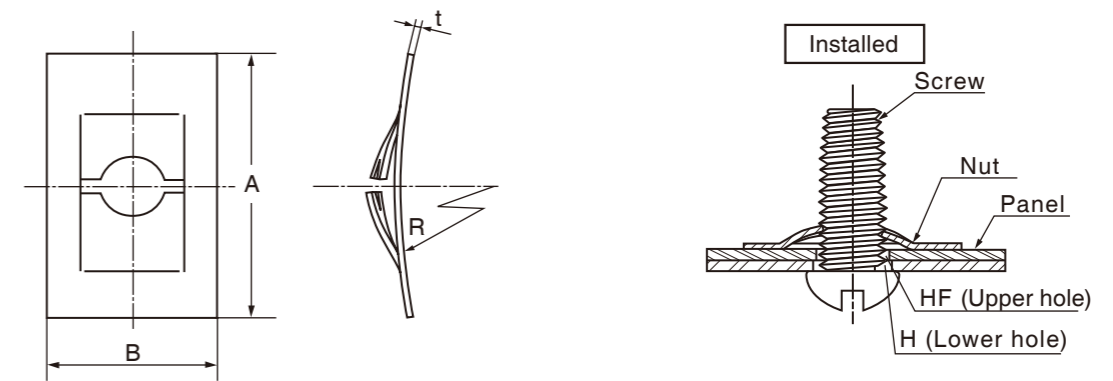

| Size No. | Applicable screw (Note 1) | Nuts | | | | Panel size | |
|----------|---------------------------|------|----|----|------|------------|----|
| | | A | B | R | t | H | HF |
| F5N-3001 | M3 × 0.5 | 16 | 10 | 40 | 0.3 | 3.2 | 4 |
| 4001 | M4 × 0.7 | 20 | 13 | 50 | 0.4 | 4.3 | 5 |
| 5001 | M5 × 0.8 | 20 | 13 | 50 | 0.45 | 5.3 | 6 |
| 6001 | M6 × 1 | 20 | 13 | 50 | 0.5 | 6.4 | 7 |

Material = Carbon spring steel

Notes

1. Refer to the JIS standard for the thread size.
2. Our products with little marketability may not be in stock. When employing our products, consult with us for their availability.

RETAINING RINGS | PUSH NUTS | WAVE WASHERS AND OTHERS | SCREW TYPE PLATE NUTS | SPRING PINS | SNAP PINS | JOINT CLIPS | JIGS