

丸S形止め輪

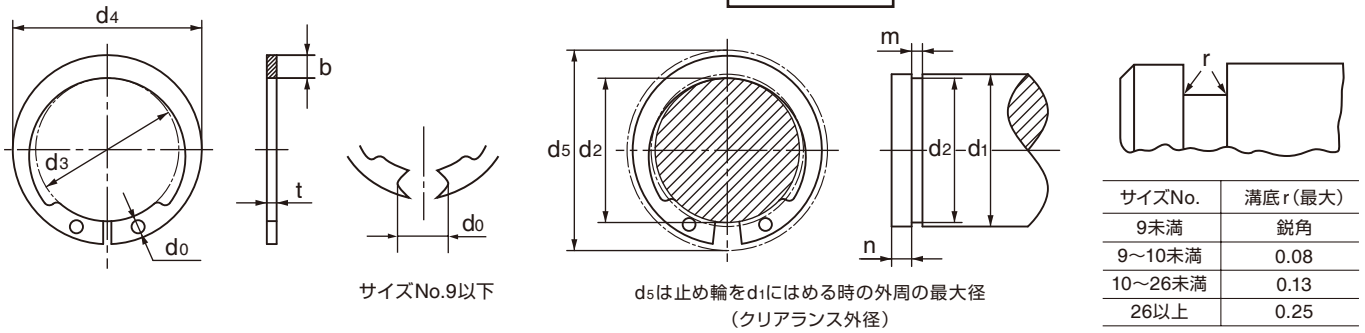

単位：mm

サイズ No.	止 め 輪							適 用 する 軸							
	d_3		d_4 (参考)	t		b	d_0	公差	d_5	d_1	d_2		m		n
	基本寸法	公差		基本寸法	公差						基本寸法	公差	基本寸法	公差	
ISTW- 6	5.6		8	0.5	± 0.03	1.2	2.2	± 0.2	8.9	6	5.7	-0.04	0.6	$+0.1$ 0	1.5
7	6.5	$+0.1$	9.3	0.6	± 0.04	1.4	2.6		10	7	6.7	0	0.7		1.5
8	7.4	-0.2	10.6	0.7		1.6	3		12	8	7.6	-0.06	0.8		1.5
9	8.4		12	0.8		1.8	3.4	13	9	8.6		0.95	1.5		
10	9.3	± 0.15	13.3	1	± 0.05	2	1.2	15	10	9.6	-0.09	1.15	1.5		
11	10.2		14.4	1		2.1	1.2	16	11	10.5		1.15	1.5		
12	11.1		15.5	1		2.2	1.2	17	12	11.5		1.15	1.5		
13	12	± 0.18	16.6	1	± 0.3	2.3	1.2	18	13	12.4		1.15	1.5		
14	12.9		17.5	1		2.3	1.2	19	14	13.4	0	1.15	1.5		
15	13.8		18.6	1		2.4	1.2	21	15	14.3	-0.11	1.15	1.5		
16	14.7	± 0.2	19.7	1	± 0.4	2.5	1.2	22	16	15.2		1.15	1.5		
17	15.7		20.9	1		2.6	1.2	23	17	16.2		1.15	1.5		
18	16.5		21.9	1.2		2.7	1.5	24	18	17		1.35	1.5		
19	17.5	± 0.2	23.1	1.2	± 0.06	2.8	1.5	25	19	18		1.35	1.5		
20	18.5		24.3	1.2		2.9	1.5	27	20	19		1.35	1.5		
21	19.5		25.5	1.2		3	1.5	28	21	20		1.35	1.5		
22	20.5	± 0.25	26.5	1.2	± 0.4	3	1.5	29	22	21		1.35	1.5		
24	22.2		28.6	1.2		3.2	1.5	32	24	22.9	0	1.35	1.7		
25	23.2		29.8	1.2		3.3	1.5	33	25	23.9	-0.21	1.35	1.7		
26	24.2	± 0.4	31	1.2	± 0.07	3.4	1.5	34	26	24.9		1.35	1.7		
28	25.9		33.1	1.5		3.6	1.8	37	28	26.6		1.65	2.1		
30	27.9		35.3	1.5		3.7	1.8	39	30	28.6		1.65	2.1		
32	29.6	± 0.25	37.4	1.5	± 0.5	3.9	1.8	41	32	30.3		1.65	$+0.14$ 0		
34	31.5		39.7	1.5		4.1	1.8	44	34	32.3		1.65	2.6		
35	32.2		40.6	1.5		4.2	1.8	45	35	33		1.65	3		
36	33.2	± 0.4	41.6	1.75	± 0.07	4.2	2	46	36	34		1.9	3		
38	35.2		44	1.75		4.4	2	48	38	36	0	1.9	3		
40	37		46.2	1.75		4.6	2	51	40	38	-0.25	1.9	3		
42	38.5	± 0.4	48.1	1.75	± 0.07	4.8	2	54	42	39.5		1.9	3.8		
45	41.5		51.3	1.75		4.9	2	57	45	42.5		1.9	3.8		
48	44.5		55.1	1.75		5.3	2	61	48	45.5		1.9	3.8		
50	45.8	± 0.45	56.8	2	± 0.08	5.5	2.5	63	50	47		2.2	4.5		
52	47.8		59	2		5.6	2.5	65	52	49		2.2	4.5		
55	50.8		62.6	2		5.9	2.5	69	55	52		2.2	4.5		
58	53.8	± 0.45	66	2	± 0.08	6.1	2.5	72	58	55		2.2	4.5		
60	55.8		68.4	2		6.3	2.5	75	60	57		2.2	4.5		
62	57.8		70.8	2		6.5	2.5	77	62	59		2.2	4.5		
63	58.8	± 0.45	72	2	± 0.08	6.6	2.5	78	63	60		2.2	4.5		
65	60.8		74.4	2.5		6.8	3	81	65	62	0	2.7	4.5		
68	63.5		77.5	2.5		7	3	84	68	65	-0.3	2.7	4.5		
70	65.5	± 0.45	79.9	2.5	± 0.08	7.2	3	87	70	67		2.7	4.5		
75	70.5		85.7	2.5		7.6	3	92	75	72		2.7	4.5		
80	74.5		90.5	2.5		8	3	98	80	76.5		2.7	5.3		

材質：ばね用鋼 硬さ：44~52HRC 表面処理：ACP(磷酸塩被膜)

< 注意点 >

- ISTW-58以上は、受注生産となります。
- 市場性の無い製品は在庫が無い場合があります。ご購入の際は事前にご確認ください。