

E-Rings

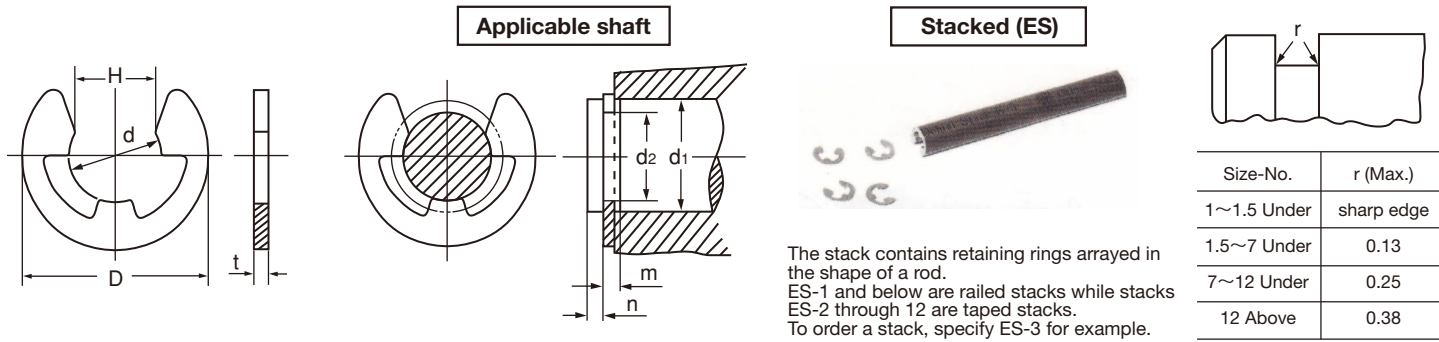

The stack contains retaining rings arrayed in the shape of a rod.
 ES-1 and below are railed stacks while stacks ES-2 through 12 are taped stacks.
 To order a stack, specify ES-3 for example.

Size-No.	r (Max.)
1~1.5 Under	sharp edge
1.5~7 Under	0.13
7~12 Under	0.25
12 Above	0.38

Unit : mm

Size-No.	Ring dimension								Applicable shaft									
	d		D		H		t		Class of d ₁		d ₂		m		n			
	Basic	Tol.	Basic	Tol.	Basic	Tol.	Basic	Tol.	Over	Under	Basic	Tol.	Basic	Tol.	Min.			
ETW- ※ 0.6	0.6	±0.02	1.5	±0.1	0.45	±0.02	0.2	±0.02	0.8	1	0.65	+0.05	0.3	+0.05	0.4			
※ 0.7	0.67	0	2		0.55	0	0.2		0.9	1.2	0.7		0.3		0.4			
0.8	0.8	-0.08	2		0.7	-0.1	0.2		1	1.4	0.82		0.3		0.4			
※ 1	0.98	-0.09	2.8	±0.2	0.88	0	0.2	±0.025	1.3	1.7	1	0	0.3	0	0.5			
1.2	1.2		3		1		0.3		1.4	2	1.23		0.4		0.6			
1.5	1.5		4		1.3		0.4		2	2.5	1.53		0.5		0.8			
※ 1.9	1.9	0	4.5	±0.3	1.7	-0.25	0.4	±0.03	2.5	3	1.93	+0.06	0.5	0	1			
2	2	-0.09	5		1.7		0.4		2.5	3.2	2.05		0.5		1			
※ 2.3	2.3	6	2		0.4		3		4	2.35	0.5		1					
2.5	2.5	-0.12	6	±0.2	2.1	0	0.4	±0.04	3.2	4	2.55	0	0.5	0	1			
3	3		7		2.6		0.6		4	5	3.05		0.7		1			
※ 3.2	3.2		7		2.8		0.6		4	5	3.25		0.7		1.2			
4	4	0	9	±0.3	3.5	-0.3	0.6	±0.05	5	7	4.05	+0.075	0.7	+0.1	1.2			
5	5	-0.12	11		4.3		0.6		6	8	5.05		0		0.7	1.2		
6	6	12	5.2		0.8		7		9	6.05	0.9		0		1.2			
7	7	-0.15	14	±0.2	6.1	0	0.8	±0.06	8	11	7.1	+0.09	0.9	0	1.5			
8	8		16		6.9		0.8		9	12	8.1		0.9		1.8			
9	9		18		7.8		0.8		10	14	9.1		0		2			
10	10	-0.21	20	±0.3	8.7	-0.35	1	±0.07	11	15	10.15	0	1.15	+0.14	2			
12	12		0		23		10.4		0	1	13		18		12.15	+0.11	1.15	2.5
15	15		-0.18		29		13		-0.45	1.5	±0.06		16		24	15.15	0	1.65
19	19	0	37	±0.3	16.5	0	1.5	±0.07	20	31	19.15	+0.13	1.65	0	3.5			
24	24	-0.21	44		20.8		0		2	25	38		24.15		0	2.2	4	

Material = Carbon spring steel. Hardness = HRC44~53. Finish = Zinc Plate plus Chromate, Phosphate coating (ACP).
 Material = Stainless steel for spring.

Notes

- The Size-Nos. with ※ mark and the d₂ dimension values stand for our Ochiai's specification.
- ETW is bulk in small bags, ES is stacked.
- The stack packages for the E Ring include 3 types of stacks according to the size and material.
 - The package for ES-0.6 to ES-1 is stacked in a rail.
 - The package for ES-1.2 to ES-12 is stacked with paper tape.
 - The stainless package consists of rings of up to 10 dia. stacked with vinyl tape.
 - When requesting stack products, specify them.
- Our products with little marketability may not be in stock. When employing our products, consult with us for their availability.