

穴用C形止め輪 [RTW-6~65]

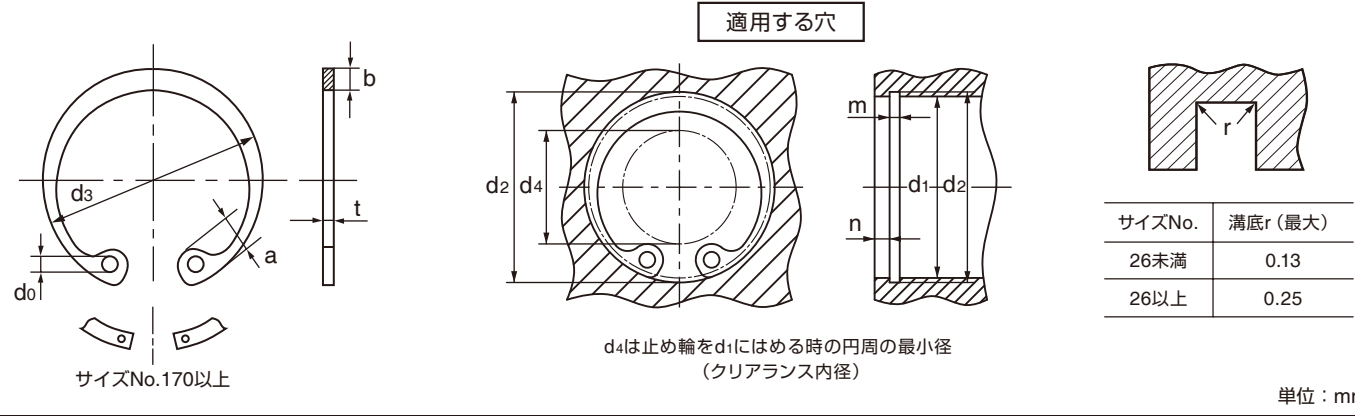

サイズ No.	止め輪						適用する穴							
	d3		t		b	a	d0	d4 (参考)	d1	d2		m		参考n
	基本寸法	公差	基本寸法	公差	約	約	最小			基本寸法	公差	基本寸法	公差	最小
RTW- 6	6.7		0.4		0.7	1.6	0.8	2.5	6	6.25	^{+0.04} ₀	0.5		0.5
7	7.7		0.4	±0.03	0.8	1.7	0.8	3	7	7.3		0.5		0.5
8	8.8		0.4		0.9	1.7	0.8	3.5	8	8.4	+0.06	0.5	0	0.6
9	9.8		0.6	±0.04	1.1	2.2	0.8	4	9	9.4	0	0.7		0.6
10	10.7		1		1.5	2.8	1.2	4	10	10.4		1.15		0.6
11	11.8	±0.18	1		1.5	3	1.2	4	11	11.4		1.15		0.6
12	13		1		1.7	3.1	1.5	5	12	12.5		1.15		0.8
13	14.1		1		1.7	3.1	1.5	6	13	13.6	+0.11	1.15		0.9
14	15.1		1		1.9	3.6	1.7	6.4	14	14.6	0	1.15		0.9
15	16.2		1		1.9	3.6	1.7	7.4	15	15.7		1.15		1.1
16	17.3		1	±0.05	1.9	3.7	1.7	8	16	16.8		1.15		1.2
17	18.3		1		1.9	3.8	1.7	9	17	17.8		1.15		1.2
18	19.5		1		2.4	4	1.7	10	18	19		1.15		1.5
19	20.5		1		2.5	4	2	11	19	20		1.15		1.5
20	21.5		1		2.5	4	2	12	20	21		1.15		1.5
21	22.5	±0.2	1		2.5	4.1	2	12	21	22	+0.21	1.15		1.5
22	23.5		1		2.5	4.1	2	13	22	23	0	1.15		1.5
24	25.9		1.2		2.5	4.3	2	15	24	25.2		1.35		1.8
25	26.9		1.2		3	4.4	2	16	25	26.2		1.35		1.8
26	27.9		1.2		3	4.6	2	16	26	27.2		1.35		1.8
27	29.1		1.2		3	4.6	2	17	27	28.4		1.35		2.1
28	30.1		1.2		3	4.6	2	18	28	29.4		1.35		2.1
30	32.1		1.2		3	4.7	2	20	30	31.4		1.35		2.1
32	34.4	±0.25	1.2	±0.06	3.5	5.2	2.5	21	32	33.7		1.35	+0.14	2.6
34	36.5		1.5		3.5	5.2	2.5	23	34	35.7		1.65	0	2.6
35	37.8		1.5		3.5	5.2	2.5	24	35	37		1.65		3.0
36	38.8		1.5		3.5	5.2	2.5	25	36	38		1.65		3.0
37	39.8		1.5		3.5	5.2	2.5	26	37	39	+0.25	1.65		3.0
38	40.8		1.5		4	5.3	2.5	27	38	40	0	1.65		3.3
40	43.5	±0.4	1.75		4	5.7	2.5	28	40	42.5		1.9		3.8
42	45.5		1.75		4	5.8	2.5	30	42	44.5		1.9		3.8
45	48.5		1.75		4.5	5.9	2.5	33	45	47.5		1.9		3.8
46	49.7		1.75		5	6.1	2.5	33	46	48.5		1.9		3.8
47	50.5		1.75		4.5	6.1	2.5	34	47	49.5		1.9		3.8
48	51.5		1.75		4.5	6.2	2.5	35	48	50.5		1.9		4.5
50	54.2		2	±0.07	4.5	6.5	2.5	37	50	53		2.2		4.5
52	56.2		2		5.1	6.5	2.5	39	52	55		2.2		4.5
55	59.2		2		5.1	6.5	2.5	41	55	58		2.2		4.5
56	60.2	±0.45	2		5.1	6.6	2.5	42	56	59	+0.3	2.2		4.5
58	62.2		2		5.1	6.8	2.5	44	58	61	0	2.2		4.5
60	64.2		2		5.5	6.8	2.5	46	60	63		2.2		4.5
62	66.2		2		5.5	6.9	2.5	48	62	65		2.2		4.5
63	67.2		2		5.5	6.9	2.5	49	63	66		2.2		4.5
65	69.2		2.5	±0.08	5.5	7	2.5	50	65	68		2.7		4.5

穴用C形止め輪 [RTW-68~300]



単位：mm

サイズ No.	止め輪						d4 (参考)	適用する穴						
	d3		t		b	a		d0	d1	d2		m		参考n
	基本寸法	公差	基本寸法	公差	約	約		最小		基本寸法	公差	基本寸法	公差	最小
RTW- 68	72.5		2.5		6	7.4	2.5	53	68	71		2.7		4.5
70	74.5	±0.45	2.5		6	7.4	2.5	55	70	73	+0.3	2.7		4.5
72	76.5		2.5		6.6	7.4	2.5	57	72	75	0	2.7		4.5
75	79.5		2.5	±0.08	6.6	7.8	2.5	59.2	75	78		2.7	+0.14	4.5
78	82.5		2.5		6.6	8	2.5	62	78	81		2.7	0	4.5
80	85.5		2.5		7	8	2.5	64	80	83.5		2.7		5.3
82	87.5		2.5		7	8	3	66	82	85.5		2.7		5.3
85	90.5		3		7	8	3	69	85	88.5		3.2		5.3
88	93.5		3		7.6	8.2	3	71	88	91.5	+0.35	3.2		5.3
90	95.5		3		7.6	8.3	3	73	90	93.5	0	3.2		5.3
92	97.5		3		8	8.3	3	74	92	95.5		3.2		5.3
95	100.5	±0.55	3		8	8.5	3	77	95	98.5		3.2		5.3
98	103.5		3		8.3	8.7	3	80	98	101.5		3.2		5.3
100	105.5		3		8.3	8.8	3	82	100	103.5		3.2	+0.18	5.3
102	108		4		8.9	9	3	83	102	106		4.2	0	6.0
105	112		4		8.9	9.1	3	86	105	109		4.2		6.0
108	115		4		8.9	9.5	3	87	108	112	+0.54	4.2		6.0
110	117		4		8.9	10.2	3	89	110	114	0	4.2		6.0
112	119		4		8.9	10.2	3	90	112	116		4.2		6.0
115	122		4		9.5	10.2	3	94	115	119		4.2		6.0
120	127	±0.65	4		9.5	10.7	3	98	120	124		4.2		6.0
125	132		4		10	10.7	3.5	103	125	129		4.2		6.0
130	137		4		10	10.7	3.5	108	130	134		4.2		6.0
135	142		4		10.8	11	3.5	113	135	139		4.2		6.0
140	147		4		10.8	11	3.5	118	140	144		4.2		6.0
145	152		4		10.8	11	3.5	123	145	149	+0.63	4.2		6.0
150	158	+1.26	4		11.5	11.8	3.5	126	150	155	0	4.2		7.5
155	164	-0.63	4		11.5	11.8	3.5	130	155	160		4.2		7.5
160	169		4		12	12.5	3.5	134	160	165		4.2	+0.2	7.5
165	174.5		4		12	12.7	3.5	139	165	170		4.2	0	7.5
170	179.5		4		12	-	3.5	145	170	175		4.2		7.5
175	184.5		4		12.5	-	3.5	149	175	180		4.2		7.5
180	189.5		4		13	-	4	153	180	185		4.2		7.5
185	194.5		4		13.5	-	4	157	185	190		4.2		7.5
190	199.5		4		13.5	-	4	162	190	195		4.2		7.5
195	204.5	+1.44	4		13.5	-	4	167	195	200	+0.72	4.2		7.5
200	209.5	-0.72	4		14	-	4	171	200	205	0	4.2		7.5
210	222		5		14	-	4	181	210	216		5.2		9.0
220	232		5		14	-	4	191	220	226		5.2		9.0
230	242		5		14	-	4	201	230	236		5.2		9.0
240	252		5		14	-	4	211	240	246		5.2		9.0
250	262		5		14	-	4	221	250	256		5.2	+0.25	9.0
260	275	+1.62	5		16	-	4	227	260	268		5.2	0	12.0
270	285	-0.81	5		16	-	4	237	270	278	+0.81	5.2		12.0
280	295		5		16	-	4	247	280	288	0	5.2		12.0
290	305		5		16	-	4	257	290	298		5.2		12.0
300	315		5		16	-	4	267	300	308		5.2		12.0

材質：ばね用鋼 ・ RTW-200まで
 硬さ：44~53HRC 表面処理：ACP(磷酸塩被膜)
 ・ RTW-210以上
 硬さ：40~50HRC 表面処理：ACP(磷酸塩被膜)

< 注意点 >

市場性の無い製品は在庫が無い場合があります。ご購入の際は事前にご確認ください。

止め輪
 ワッシャー | ウェブワッシャー | ねじ式スリーブワッシャー | スクリューピン | スチールピン | クロムワッシャー | 工業